

Waters™

應用手冊

Improving a High Sensitivity Assay for the Quantification of Teriparatide in Human Plasma Using the ionKey/MS System

Mary E. Lame, Erin E. Chambers

Waters Corporation



Abstract

This study combines μ Elution SPE and the novel and highly efficient ionKey/MS system to improve a quantitative assay for teriparatide in human plasma.

The combination of ionKey/MS, μ Elution reversed-phase SPE, and higher m/z b or y ion MS fragments provided the level of selectivity and sensitivity necessary to accurately quantify low pg/mL concentrations of teriparatide in extracted plasma. Use of the μ Elution format SPE plate eliminated the need for evaporation, reducing teriparatide losses due to adsorption and non-specific binding.

Benefits

- High sensitivity assay with LOD of 10 pg/mL in human plasma
- Reduced solvent consumption (50X) compared to 2.1 mm scale means significant cost savings
- Use of solid-phase extraction (SPE) reduces matrix interferences and enhances selectivity of the extraction for teriparatide in plasma
- 96-well μ Elution plate format enables concentration of the sample while maintaining solubility and minimizes peptide losses due to adsorption
- Selective, fast SPE extraction (<30 minutes) without time-consuming immuno-affinity purification
- Compared to 2.1 mm scale, proof of concept studies yield 4X greater S:N from 4X less sample and half the injection volume allowing for greater confidence in results, more tests per sample, and more injections

Introduction

Teriparatide (FORTEO), Figure 1, is a recombinant form of a fragment of human parathyroid hormone, used in the treatment of osteoporosis. Osteoporosis is responsible for 1.5 million bone fractures a year and teriparatide is the first treatment that stimulates new bone formation. It is an anabolic drug that acts to build up bones and has the potential to improve skeletal micro architecture and increase bone density. Teriparatide is the first 34 amino acids (the biologically active region) of the 84-amino acid human parathyroid hormone (PTH), and is also referred to as, rhPTH (1-34).¹

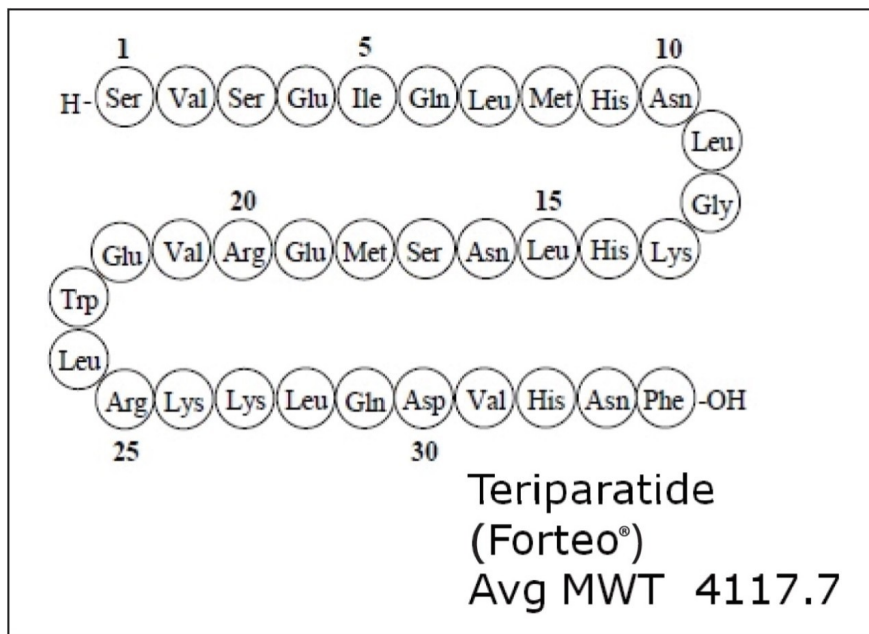

Figure 1. Representative structure and amino acid sequence of teriparatide.

Although biologics have historically been quantified using ligand binding assays (LBAs), over the past few years, there has been a trend toward the analysis of large molecules by LC-MS/MS. This is, in part, driven by the fact that LBAs can suffer from significant cross-reactivity issues and lack of standardization. LC-MS/MS has the advantage of shorter development times, greater accuracy and precision, the ability to multiplex, and can readily distinguish between closely related analogues, metabolites or endogenous interferences.

Experimental

Sample preparation

Samples were pretreated using protein precipitation (PPT) and extracted on an Oasis HLB 96-well μ Elution Plate, 2 mg Sorbent per Well, 30 μ m (p/n 186001828BA) particle size according to a previously published method.³

UPLC conditions

LC system:

ACQUITY UPLC M-Class with 2D Technology
configured with optional trap and back flush
elution

Separation device:	iKey Peptide BEH C ₁₈ Separation Device, 130Å, 1.7 μm, 150 μm x 50 mm (p/n 186006764)
Trap column:	ACQUITY UPLC M-Class Symmetry C ₁₈ Trap Column, 100Å, 5 μm, 300 μm x 50 mm (p/n 186007498)
Mobile phase A:	0.1% formic acid in water
Mobile phase B:	0.1% formic acid in acetonitrile
Loading solvent:	95:5 mobile phase A:B, 35 μL/min for first two minutes, reverse valve
Valve position:	Initial position one (forward loading of trap), switch to position two at two minutes (back flush elute of trap onto the analytical column)
Final optimized analytical gradient:	See Table 1
Elution flow rate:	2.0 μL/min
iKey temp.:	75 °C
Sample temp.:	15 °C
Final injection vol.:	15 μL
Total run time:	13.0 minutes
Collection plates:	Waters 1 mL Collection Plates (p/n 600001043)

Time (min)	Flow rate (μL/min)	Composition A (%)	Composition B (%)	Curve
0.00	2.0	85	15	Initial
5.00	2.0	55	45	6
6.00	2.0	5	95	6
8.00	2.0	5	95	6
9.00	2.0	85	15	6

Table 1. UPLC gradient conditions.

MS conditions

MS system:	Xevo TQ-S
Ionization mode:	ESI positive
Capillary voltage:	3.6 kV
Source temp.:	120 °C
Cone gas flow:	50 L/hr
Collision cell pressure:	3.83 x 10 ⁽⁻³⁾ mbar
Collision energy:	Optimized by component, see Table 2
Cone voltage:	Optimized by component, see Table 2

Peptide	MRM transition	Cone voltage (V)	Collision energy (eV)
Teriparatide	687.05 > 787.26	45	18
	824.25 > 983.79	45	25
Human Parathyroid 1-38 (ISTD)	637.58 > 712.61	45	11
	892.22 > 854.80	45	21

Table 2. MRM transitions, collision energies, and cone voltages for teriparatide and human parathyroid hormone 1-38 [rhPTH (1-38)], the IS.

Data management

Chromatography software: MassLynx 4.1

Quantification software: TargetLynx

The need for robust and sensitive analysis of peptide species challenges both chromatographic separation and mass spectrometry. Peptides, in general, are often difficult to analyze by LC-MS/MS, as MS sensitivity is low due to the formation of multiple precursors and poor or overly extensive fragmentation, making LC and sample preparation even more critical. In addition, teriparatide also suffers from significant non-specific binding and poor solubility, making LC and sample preparation method development challenging.

The pharmacokinetics of teriparatide are characterized by rapid absorption within 30 minutes and rapid elimination with a half-life of 1 hour, resulting in a total duration of exposure (to the peptide) of approximately 4 hours.^{1,2} At the practical clinical dose of 20 µg the typical teriparatide levels are ~50 pg/mL, which makes detection by traditional LC-MS/MS even more difficult.

Through a combination of selective sample preparation, optimal MS precursor and fragment choice, and UPLC separation on a charged surface column, we developed and published an analytical scale method for accurate, precise, teriparatide quantification with a detection limit of 15 pg/mL.³ In this current work however, we undertook to a) transfer this method to the ionKey/MS System (phase 1), and b) further improve the method through the inherent characteristics of the ionKey/MS System (phase 2). This technology integrates the UPLC analytical separation directly into the source of the mass spectrometer (Figure 2). The iKey Separation Device (150 µm I.D.), shown in Figure 3, contains the fluidic channel, electronics, ESI interface, heater, eCord, and the chemistry to perform UPLC separations. Additionally, the ionKey/MS System can provide increased sensitivity compared to 2.1 mm I.D. chromatography with the same injection volume, or equivalent or greater sensitivity with reduced sample consumption, making it ideal for peptide analyses. It is common for bioanalytical LC-MS assays to consume high volumes of both solvent and sample, thus increasing the cost of the assay and limiting the number of replicates that can be analyzed. This study combines µElution SPE and the novel and highly efficient ionKey/MS System to improve a quantitative assay for teriparatide in human plasma. In phase 1, we will demonstrate the effective transfer of the previously developed analytical method using a 200 µL sample size to the ionKey/MS System. Results will show that we can readily achieve a limit of detection (LOD) of 10 pg/mL with a linear dynamic range of 10–3,000 pg/mL in human plasma, using 1/3 of the injection volume. Mean accuracy and precision of quality control samples were 102.9 and 3.5%, respectively. In phase 2, we show proof of concept for further method improvement, fully capitalizing on the attributes of the ionKey/MS System to reduce the sample volume by 4X, reduce injection volume by half, and increase signal-to-noise (S:N) by 4X over the 2.1 mm

I.D. scale.



Figure 2. ionKey/MS System: comprised of the Xevo TQ-S, the ACQUITY UPLC M-Class, the ionKey Source, and the iKey Separation Device.



Figure 3. iKey Separation Device.

Results and Discussion

Mass spectrometry

Several multiple-charged precursors were observed for teriparatide and rhPTH (1-38). The 6+ charge state of teriparatide at m/z 687.05 was determined to be the most intense and yielded a selective fragment at m/z 787.26 for quantitative analysis. The 7+ precursor at m/z 589 was also intense, but did not yield any useable fragments. CID of the 5+ precursor at m/z 824.25 produced fragment ions of sufficient intensity to be used for confirmatory purposes. The 6+ charge state of the IS [rhPTH(1-38)] at m/z 637.58 and its fragment ion at m/z 712.51 was used

for quantitation. Although many peptides produce intense fragments below m/z 200, these ions (often immonium ions) result in high background in extracted samples due to their lack of specificity. In this assay, the use of highly specific y ion fragments above m/z 700 yielded significantly improved specificity, facilitating the use of simpler SPE methodologies.

Phase I. Initial chromatographic separation

Chromatographic separation of teriparatide and its IS was achieved using the novel microfluidic chromatographic iKey Separation Device. The iKey Separation Device has a channel with UPLC-grade, sub-2- μm particles that permits operation at high pressure and results in highly efficient LC separations. By integrating microscale LC components into a single platform design, problems associated with capillary connections, including manual variability, leaks, and excessive dead volume are avoided. iKey Peptide BEH C_{18} Separation Device, 130 \AA , 1.7 μm , 150 μm x 50 mm (p/n 186006764) provided excellent peak shape, narrow peak widths (<2.5 secs at base), and resolution from endogenous matrix interferences.

Representative chromatograms of teriparatide and the IS, eluted using an initial linear gradient from 8 to 65% B over 5 minutes, on an iKey Peptide BEH C_{18} Separation Device, 130 \AA , 1.7 μm , 150 μm x 50 mm (p/n 186006764), are shown in Figure 4. These samples were extracted from 200 μL of sample and 10 μL was injected. This corresponded to injecting 1/3 of the sample required for the 2.1 mm I.D. scale, but extracting the same sample volume. The use of multidimensional chromatography, specifically a trap and back-elute strategy, provided further sample cleanup and facilitated the loading of 10–15 μL of the high organic SPE eluate (required to maintain solubility of the peptides) without experiencing analyte break through. Additionally, the ability to inject the larger sample volumes typical for analytical scale LC analysis on the iKey Separation Device can provide the substantial gains in sensitivity that are often required to accurately and reliably detect low pg/mL levels of peptide and protein in complex matrices.

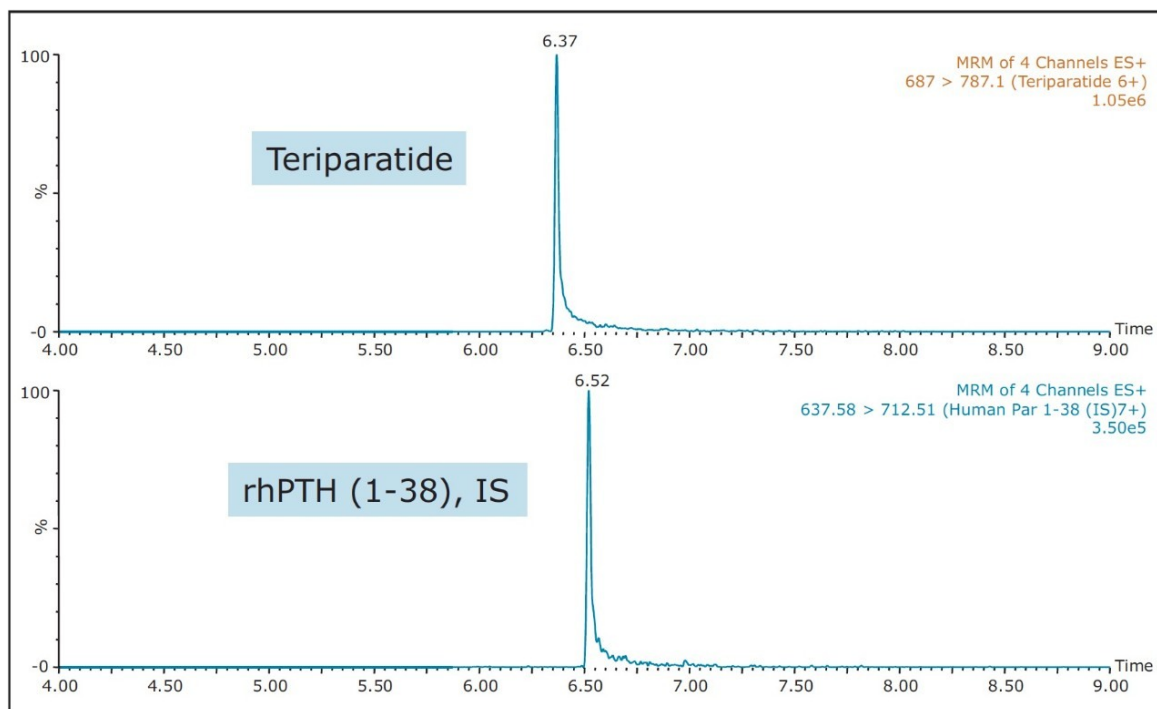

Figure 4. UPLC separation of teriparatide and IS, from extracted plasma, using the iKey Peptide BEH C₁₈ Separation Device, 130Å, 1.7 µm, 150 µm x 50 mm (p/n 186006764).

Sample preparation

Development of this assay was challenging due to non-specific binding (NSB) and maintenance of peptide solubility throughout the SPE extraction and elution process. Sample pretreatment prior to SPE proved to be critical in improving recovery and specificity. Protein precipitation (1:1) with 5% NH₄OH in acetonitrile resulted in 80–100% recovery without precipitating the peptide itself. Use of Oasis HLB SPE provided a reversed-phase mode of retention, enabling sample cleanup, selectivity, concentration of the sample, and ultimate sensitivity for this peptide. Teriparatide and the IS were well retained on this SPE sorbent during the basic pH load step, with no break through occurring. Optimization of the elution solution was critical to fully elute teriparatide, maintain its solubility and minimize interferences from the plasma matrix. The optimum elution solution was 60% organic, with 1% trifluoroacetic acid, and 5% trifluoroethanol (TFE), the latter being added to maintain solubility of the compound. Additionally, the Oasis HLB 96-well µElution Plate can be processed manually in under 30 minutes and is compatible with most liquid-handling robotic systems for automation to meet sample throughput requirements. This format also provides the ability to concentrate the sample and elute in very small sample volumes, minimizing the potential for peptide losses that might occur during evaporation due to adsorption to the walls of collection plates and/or chemical instability.

Linearity, accuracy, and precision

To generate standard curves, human plasma was fortified with teriparatide at the following final concentrations: 10, 20, 40, 60, 100, 300, 600, 1,000, and 3,000 pg/mL. Each standard level was prepared in duplicate. Quality control (QC) samples (N=5) were prepared from the same plasma at 25, 50, 80, 200, and 500 pg/mL. Human parathyroid hormone 1-38 [rhPTH (1-38)] was used as the internal standard (IS). Peak area ratios (PARs) of the analyte peak area to the IS peak were calculated. The calibration curve was constructed using PARs of the calibration samples by applying a one/concentration (1/x) weighted linear regression model. Using 1/x regression, teriparatide was linear with an R² value of >0.99. A summary of standard curve performance (10–3,000 pg/mL) is shown in Table 3. All QC sample concentrations were then calculated from their PARS against the calibration curve. Results from QC analysis are shown in Table 4. Figure 5 contains representative chromatograms for QC samples containing teriparatide at 25, 50, 80, 200, and 500 pg/mL extracted from 200 µL human plasma as compared to blank extracted plasma. At all levels, QC samples demonstrated very good accuracy and precision, with mean accuracies ranging from 101.2–104.9 and mean %CV's of 2.56–5.09. These results easily meet the recommended FDA acceptance criteria outlined in the white papers describing best practices in bioanalytical method validation for LC-MS/MS assays.^{4,5}

Teriparatide concentration (pg/mL)	Teriparatide/IS ratio response	Calculated teriparatide concentration (pg/mL)	Mean accuracy
10.00	0.07	10.56	105.63
20.00	0.14	20.53	102.63
40.00	0.29	38.99	97.58
60.00	0.43	57.58	95.97
100.00	0.73	97.00	97.00
300.00	2.17	286.39	95.50
600.00	4.75	626.81	104.45
1,000.00	8.05	1061.49	106.15
3,000.00	22.31	2937.14	97.95

Table 3. Standard curve summary and statistics from 10–3,000 pg/mL for teriparatide extracted from human plasma.

Teriparatide QC concentration (pg/mL)	Mean (N = 5) calculated concentration (pg/mL)	SD	%CV	Mean accuracy
25	25.8887	1.32	5.09	103.6
50	51.4236	1.91	3.72	102.8
80	83.8803	2.15	2.56	104.9
200	202.3569	6.49	3.20	101.2
500	511.1018	15.23	2.98	102.2

Table 4. QC statistics from teriparatide extracted from human plasma.

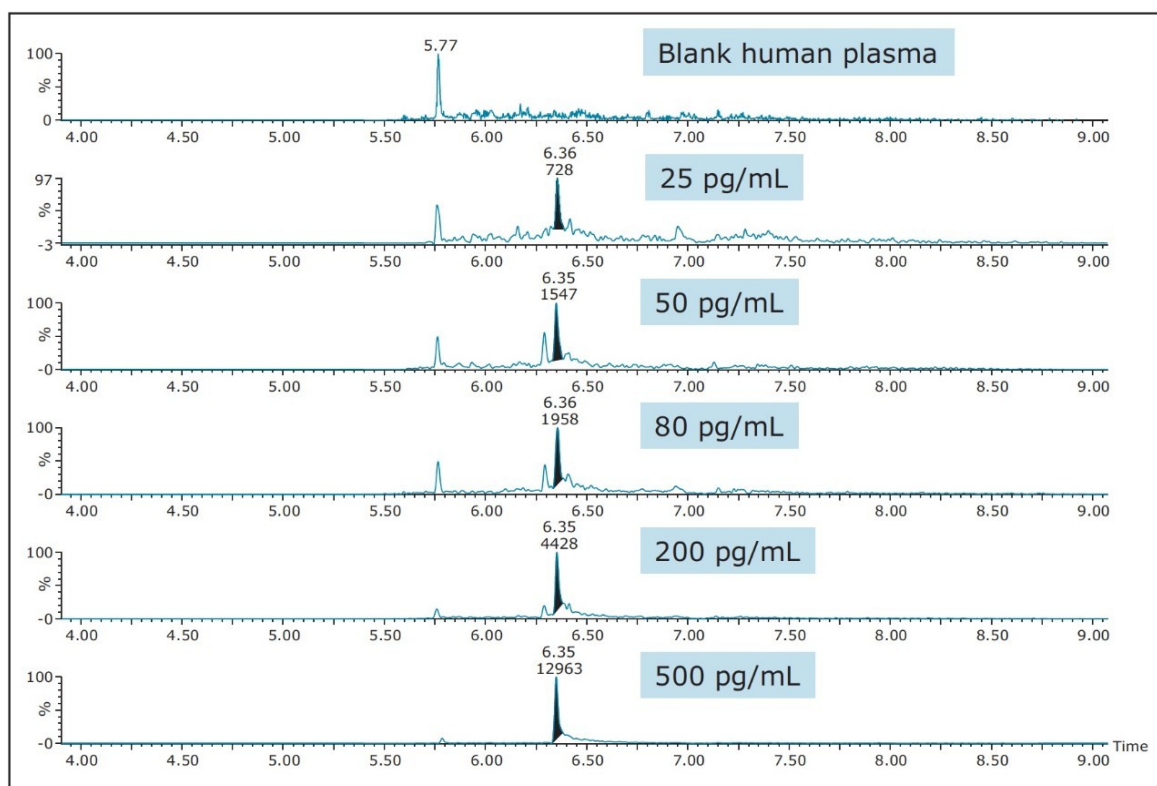

Figure 5. Representative QC chromatograms of teriparatide extracted from 200 µL of human plasma at 25, 50, 80, 200, and 500 pg/mL compared to extracted blank plasma.

Phase II. Minimizing sample requirements and reducing injection volume using the ionKey/MS System

Initial validation of the method using the ionKey/MS System demonstrated increased sensitivity over the 2.1 mm I.D. scale, which allowed us to make significant further improvements. Two of the key benefits of integrated microscale separations are the ability to maintain or improve sensitivity using smaller sample volumes, and lower injection volumes. This obviously has the advantage of preserving precious study samples or allowing one to

gain more information from each sample, especially if initial volume is limited (i.e. rat or mouse samples.) Following the original validation using 200 μ L of sample, further chromatographic refinements were made and a proof of concept study was performed where only 50 μ L of sample were extracted. Representative chromatograms from these QC samples containing teriparatide at 15, 25, and 50 pg/mL, as compared to blank extracted plasma, are shown in Figure 6. The linearity of the method ($R^2= 0.998$) extracting 50 μ L sample and injecting 15 μ L, is shown in Figure 7. Finally, S:N for a 20 pg/mL extracted sample comparing the 2.1 mm published method to the ionKey/MS System proof of concept work is shown in Figure 8. While S:N is approximately 11:1 at the 2.1 mm I.D. scale, it is 45:1 using the ionKey/MS System with 4X less sample, and half the injection volume. The cumulative sensitivity and sample reduction benefits are particularly significant for labs where ultra-high sensitivity is required, especially from small samples.

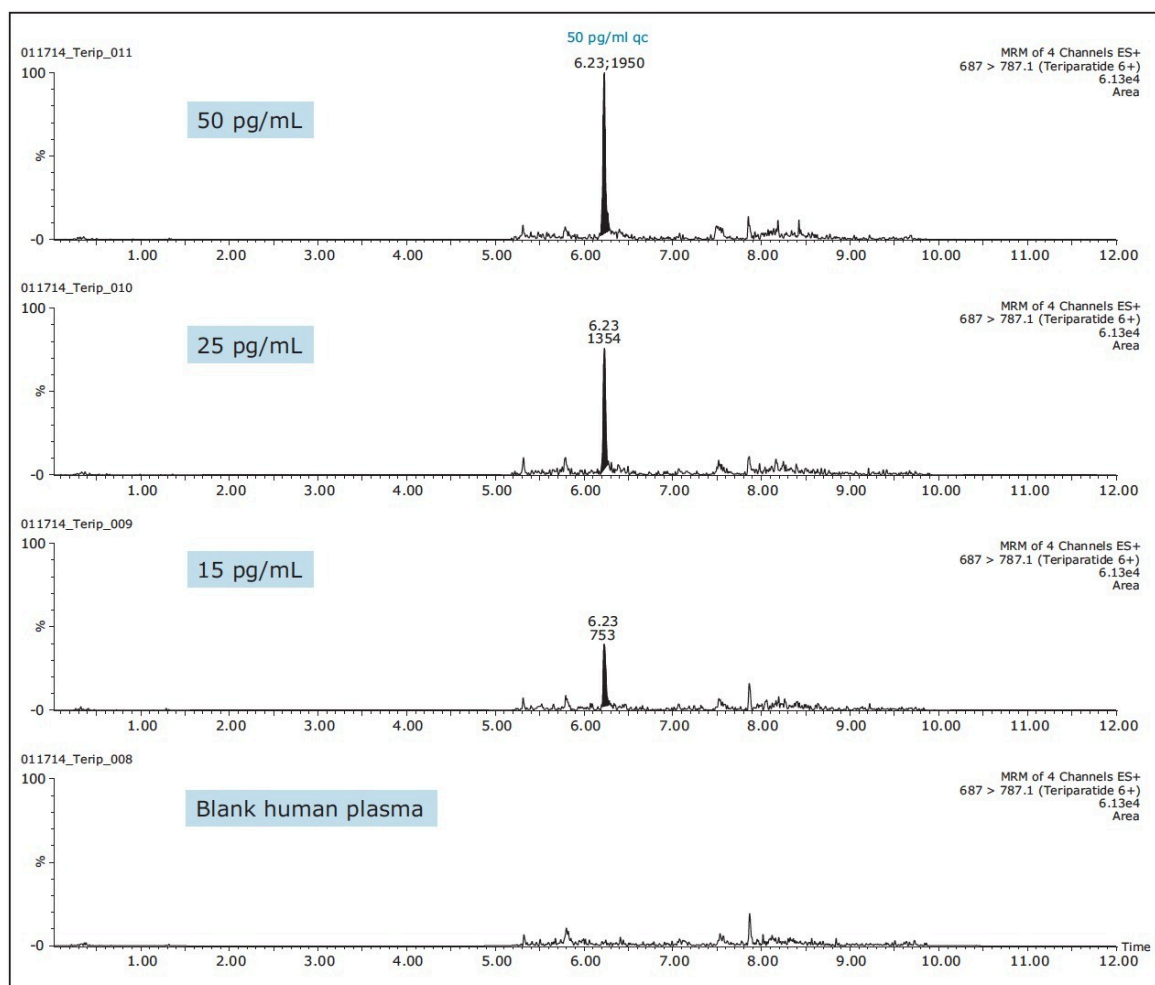

Figure 6. Representative QC chromatograms of teriparatide extracted from 50 μ L human plasma at 15, 25, and 50 pg/mL compared to extracted blank plasma.

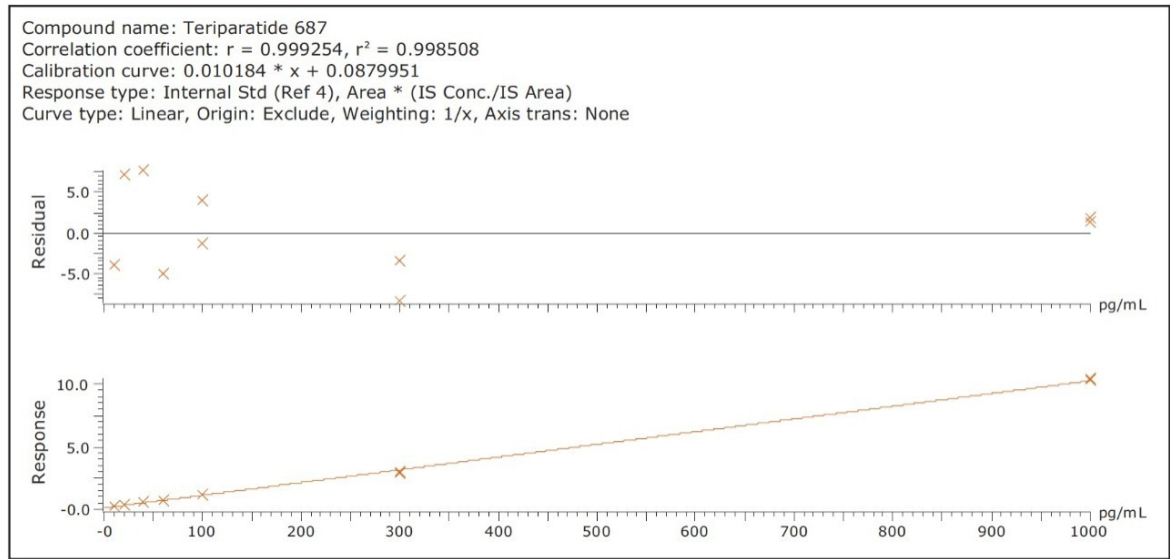

Figure 7. Linearity of the optimized ionKey/MS System assay.

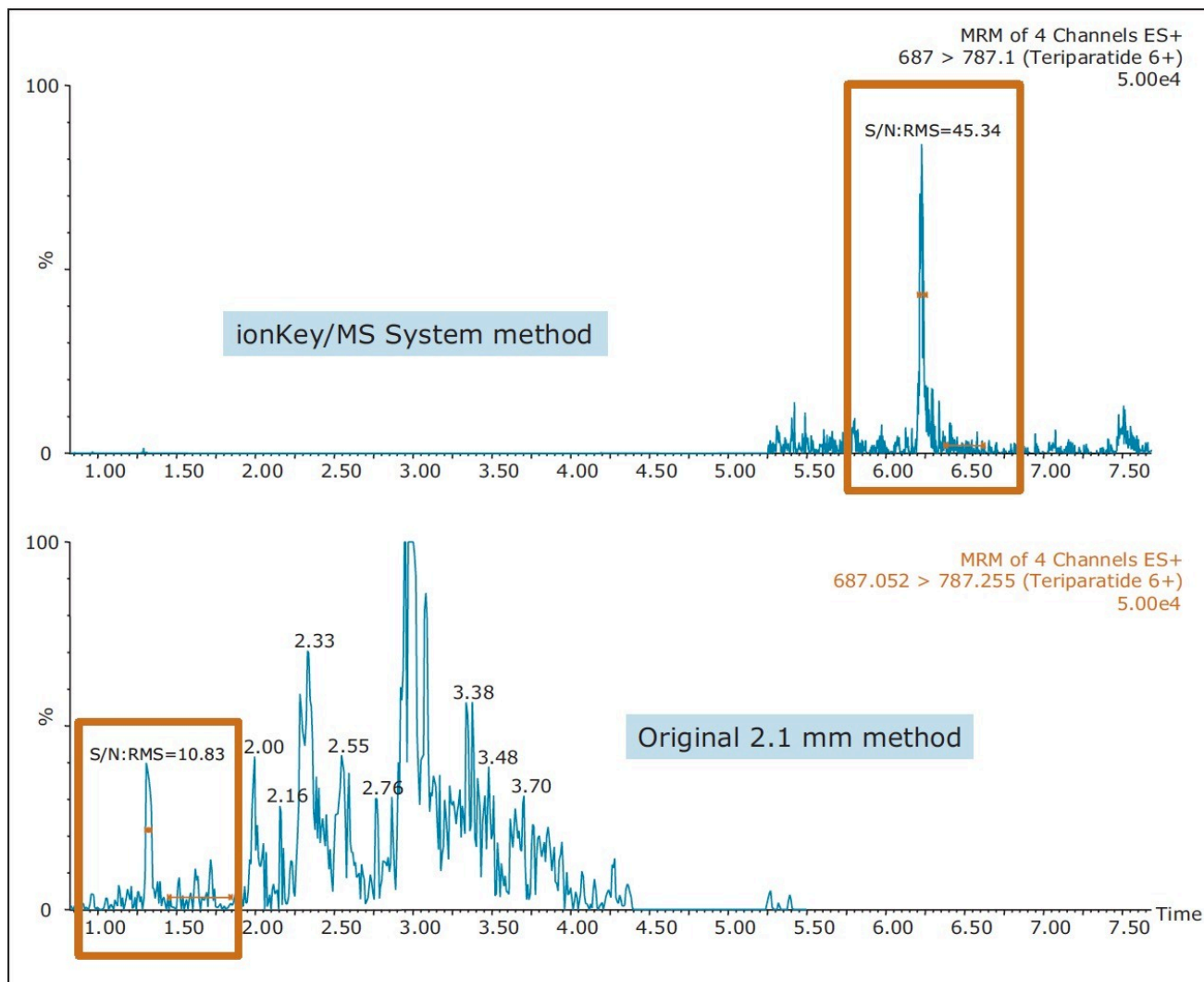

Figure 8. A comparison of 20 pg/mL teriparatide extracted from human plasma using the optimized ionKey/MS System method and an optimized 2.1 mm scale method. 50 μ L of plasma were extracted for the ionKey/MS System and 200 μ L plasma for 2.1 mm scale.

Conclusion

The combination of the ionKey/MS System, μ Elution reversed-phase SPE, and higher m/z b or y ion MS fragments provided the level of selectivity and sensitivity necessary to accurately quantify low pg/mL concentrations of teriparatide in extracted plasma. Use of the μ Elution format SPE plate eliminated the need for evaporation, reducing teriparatide losses due to adsorption and non-specific binding. The use of the 150 μ m iKey Separation Device enabled the development of a highly sensitive, quantitative MRM method for teriparatide with an LOD of 10 pg/mL from only 200 μ L of plasma with a 10 μ L injection of sample. Standard curves were accurate

and precise from 10–3,000 pg/mL. QC samples at all levels easily met recommended FDA regulatory criteria^{4,5} with mean accuracies ranging from 101.2–104.9 and mean %CV ranges of 2.56–5.09, indicating an accurate, precise, and reproducible method. The ionKey/MS System method was further optimized to provide a 4X improvement in S:N over the 2.1 mm I.D. scale using 4X less sample and half the injection volume. In addition, the ionKey/MS System also reduces solvent and sample consumption, thereby reducing cost and allowing for multiple injections of samples for improved accuracy or to meet the guidelines for ISR. This method shows great promise for high sensitivity quantification of teriparatide in patient samples from PK and clinical studies using the ionKey/MS System if further validation was performed.

References

1. Eli Lilly and Company (2009) Teriparatide [rhPTH(1–34)] (Forteo) United States package insert.
2. Satterwhite J, Heathman M, Miller PD, Marin F, Glass EV, Dobnig H. Pharmacokinetics of teriparatide (rhPTH[1–34]) and calcium pharmacodynamics in postmenopausal women with osteoporosis. *Calcif Tissue Int* 2010 Dec;87(6):485–92.
3. Chambers E, Lame M, et al., *Journal of Chromatography B*, 938 (2013) 96–104.
4. Viswanathan CT, Bansal S, Booth B, DeStefano AJ, Rose MJ, Sailstad J, Shah VP, Skelly JP, Swann PG, Weiner R, Quantitative bioanalytical methods validation and implementation: best practices for chromatographic and ligand binding assays, *Pharm. Res.*, 24 (2007) 1962–1973.
5. Bansal S, DeStefano A, Key elements of bioanalytical method validation for small molecules, *AAPS J*, 9 (2007) E109–114.

Featured Products

- [ionKey/MS <https://www.waters.com/134782630>](https://www.waters.com/134782630)
- [ACQUITY UPLC M-Class System <https://www.waters.com/134776759>](https://www.waters.com/134776759)
- [Xevo TQ-S <https://www.waters.com/10160596>](https://www.waters.com/10160596)
- [MassLynx Software <https://www.waters.com/513662>](https://www.waters.com/513662)

· [TargetLynx <https://www.waters.com/513791>](https://www.waters.com/513791)

720004948, January 2016



©2019 Waters Corporation. All Rights Reserved.