

Note d'application

## The Use of PATROL UPLC Process Analysis System for Continuous Flow Chemistry Processes in a Pharmaceutical Company

---

Janet Hammond, Steve Preece, Jean-Michel Plankeele, Stephanie Harden, Guillaume Janin, Mubina Mohamed, Richard Hart

Waters Corporation, AstraZeneca

---

### Abstract

This application note describes the use of a PATROL UPLC Process Analysis System in the manufacture of 160kg of an intermediate pharmaceutical drug substance using a continuous flow process.

### Benefits

PATROL assists in the development of continuous flow chemistry systems. With its analysis frequency and sensitivity, PATROL provides richer quantitative processing understanding than any other spectroscopic PAT sensors or traditional offline LC testing. This added information contributes to creating process steps that ensure consistent product quality with maximum yields and minimum waste.

---

### Introduction

---

This work discusses the utility of UltraPerformance Liquid Chromatography (UPLC)-based Process Analytical Technology (PAT) systems for monitoring continuous flow reactions locally in near real time. This technology provides rich process understanding, which facilitates rapid and informed decision making.

Many pharmaceutical companies are turning to continuous flow chemistry processes over batch chemistry. The benefits of continuous flow reactions include improved product throughput, increased yield, easier process scalability, better temperature control, and a safer manufacturing process. For pharmaceutical and biopharmaceutical companies PAT is a critical component of manufacturing. It is relied upon to provide richer process understanding, consistent product quality with maximum yields, and minimal waste. When the formations of impurities are kept to a minimum, the need of isolation or purification steps on the final product may be avoided. As part of flow reaction development it is important that the process parameters are fully optimized with respect to temperature, pressure, and reactant stoichiometry and the impurity profile obtained is fully understood.

Reaction monitoring by on line spectroscopic techniques such as Raman, near-infrared (NIR) and infrared (IR) are often used because they do not disrupt the process and require little direct intervention. These techniques have the ability to provide real-time information about the reaction progression but suffer from lack of selectivity and produce little quantitative information about intermediates and low level impurities.

High performance liquid chromatography (HPLC) is a more selective and sensitive technique and has the ability to provide quantitative information. It is the most widely used analytical technique in pharmaceutical laboratories. The long run times and complex system operation have historically prevented it from being routinely used for atline or online analysis.

By utilizing online UPLC, quantitative information can be revealed about the final product and low-level impurities in a much shorter time frame while enabling quick changes of process parameters to identify those critical to optimizing flow reaction. This greater understanding of a reaction improves the scale-up process to manufacturing and ensures maximum yield and purity.

Configurable and scaleable, the PATROL UPLC Process Analysis System provides access to real-time, chromatographic-quality analysis for in-process samples. It is designed for online and/or atline UPLC analysis during process development and can be used to monitor the scale up of the flow reaction from benchtop scale, to pilot scale, through to the final manufacturing scale. It also has the benefits of managing sample specific dilutions in a programmable workflow to provide quantitative results. It can, from a single standard vial, generate multi-point calibration curves with Empower 3 Software. Workflows (sample sets) can be programmed to ensure

that system preparation and analyses are performed consistently.

This application note describes the use of a PATROL UPLC Process Analysis System in the manufacture of 160kg of an intermediate pharmaceutical drug substance using a continuous flow process. The reaction has a total residence time of 8 seconds and a flow rate of 500 grams/minute, producing a large amount of product very rapidly. The traditional approach of running an in process test (IPT)/in process control (IPC) by HPLC is not appropriate for these fast processes due to the length of the cycle time required to generate data, as well as potentially excessive amounts of product generation prior to the determination of whether or not process parameter modification is necessary.

---

## Experimental

To optimize the flow reaction process, a design of experiment (DoE) was developed varying stoichiometry and flow rates of starting materials (RM1 and RM2) (Table 1).

Starting material	Equivalents (mol)		Flow rate (mL/min)	
	Minimum	Maximum	Minimum	Maximum
RM1	-0.21	0.15	5.45	6.9
RM2	-0.21	0.15	5.45	6.9

Table 1. Stoichiometry and flow rates of starting materials RM1 and RM2 in DoE.

## Method conditions

System: PATROL UPLC Process  
Analysis System

Column: ACQUITY UPLC C<sub>18</sub> 2.1 mm x  
30 mm 1.7 μm

Column temp.: 60 °C

Sample temp.: 15 °C

Injection volume: 1 μL

Flow rate: 1.4 mL/min

Mobile phase A: Water

Mobile phase B: Acetonitrile

Mobile phase C: 1% Trifluoroacetic acid

Run time: 2.2 mins

## Gradient

Time (min)	%A	%B	%C
0.00	92	5	3
1.54	10	87	3
1.67	10	87	3
1.71	92	5	3

---

## Results and Discussion

### The use of PATROL in the laboratory

Translation of the IPC HPLC method onto a fast UPLC method was performed in preparation for incorporating the PATROL UPLC System into the continuous flow reaction workflow. The resulting UPLC method reduced the analysis time from 6 minutes to 2 minutes, details of which are outlined in the experimental section. To gain a better understanding of the impurity profile of the chemical reaction, a comprehensive series of experiments, known as a DoE was created. This studied the impact of changing the ratios and flow rates of the two starting materials (RM1 and RM2) on the critical attributes of the experiment such as yield and quality. The reaction temperature was held constant at 30 °C.

Concluded from the DoE study was the following:

- The main factors responsible for high quality product production are flow rates of the starting materials RM1 and RM2
- The largest amounts of impurities were generated when the RM1 flow was higher and RM2 lower than the center point
- The highest yield of the product is obtained when the flow of RM1 and RM2 is at the center point
- The product yield and quality decreases when the RM1 is at the highest flow rate

UV based calibration curves with both starting materials (RM1 and RM2) in the range of 0.13 to 2.5 mg/mL and the product in the range of 1.23 to 1.75 mg/mL were generated within Empower 3. Using these calibration curves, the starting materials and product were quantified in each of the results generated from the DoE.

In order to complement the traditional spectroscopic PAT tools the model is validated using an external standard assay and organic impurities method to quantify the product, the remaining starting materials and to control the reaction impurity profile during the manufacture in the large scale laboratory (LSL).

### The use of PATROL in the large scale laboratory (LSL)

In order to minimize the analysis time the PATROL system was moved from the lab into the LSL to be close to the flow reactor. A schematic of the continuous flow reaction process is shown in Figure 1. The quenched continuous reaction feed was manually sampled from the reactor and automatically diluted using the Process

Sample Manager (PSM). The analysis cycle time using the PATROL UPLC System was 3 minutes from the moment the sample was logged into Empower to the automatic integration and report generation. With a typical HPLC analysis of 10 minutes, cycle time was improved 3-fold with the use of PATROL (Figure 2). Gradient and transport time were clearly reduced with PATROL.

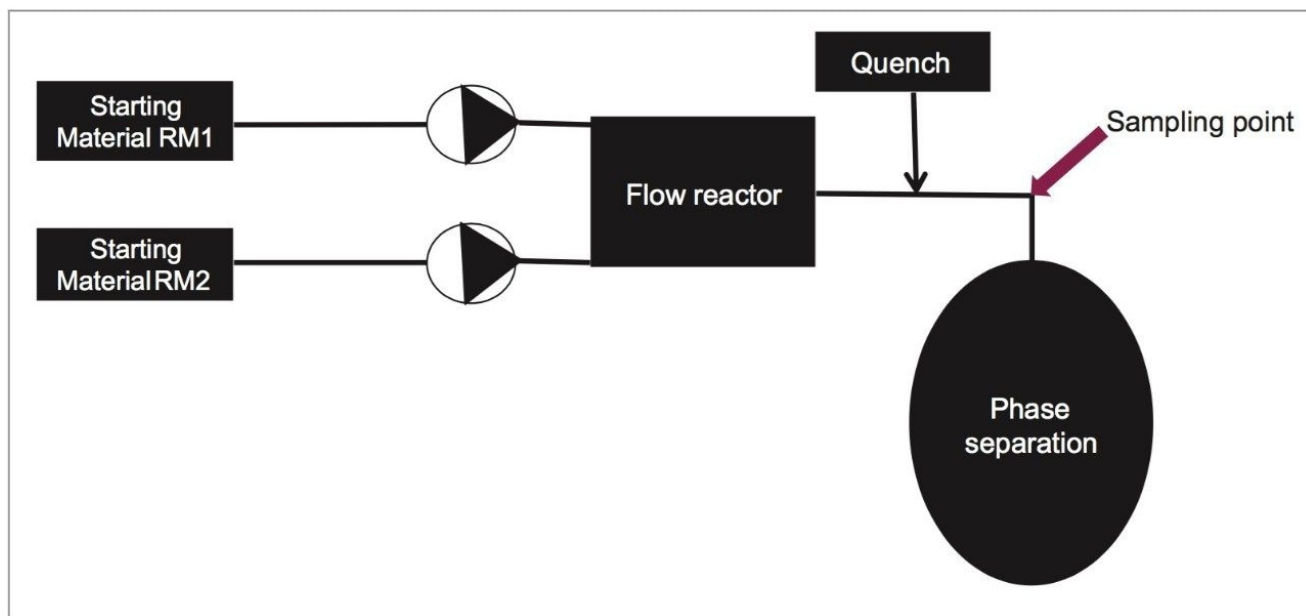

Figure 1. A schematic of the continuous flow reaction process.

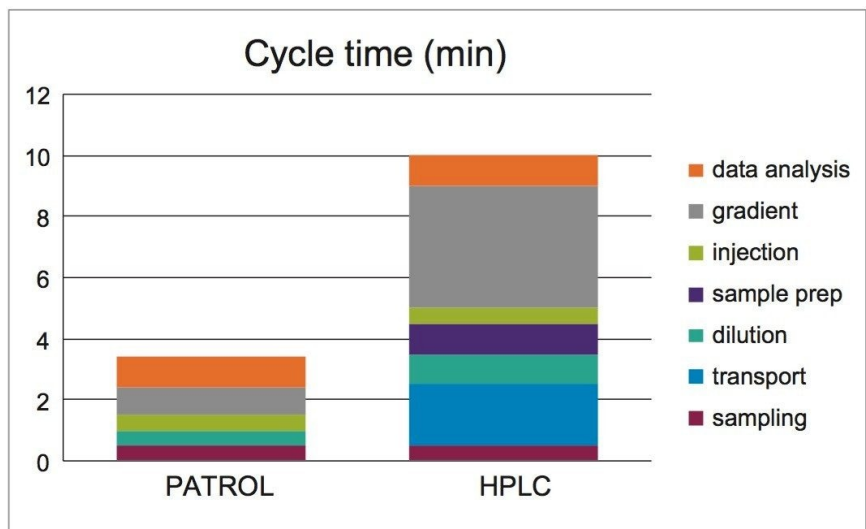

Figure 2. A comparison of time for each individual activity during the chromatographic analysis.

During the manufacture of the first batch of material in the LSL, a change in color was observed in the reaction, which had not been seen in the preliminary laboratory experiments. As a result, the traditional spectroscopic PAT tools could not be used to monitor the reaction because the differences in material quality invalidated the calibration model. With a cycle time of only 3 minutes, utilization of the PATROL UPLC System enabled a prompt decision to be made to modify the reagent flow rates in efforts to manage impurity formation and kept the loss of product to a minimum (Figure 3).

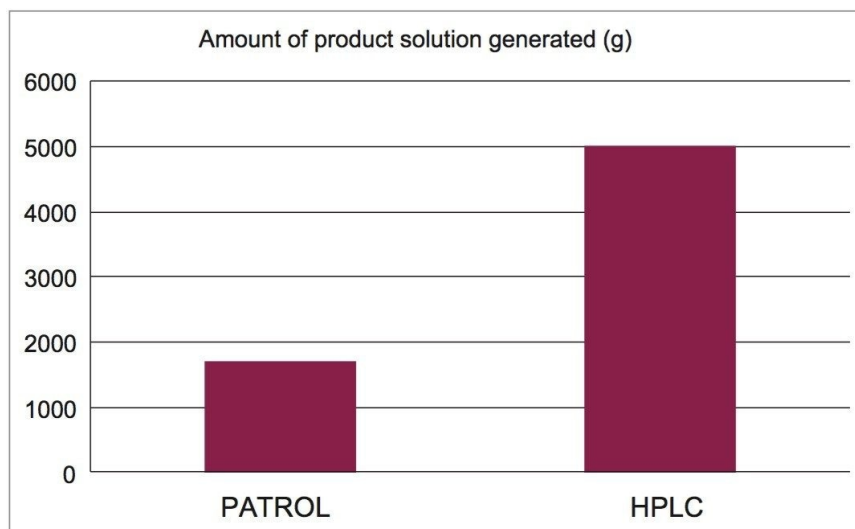

Figure 3. A comparison of product generated during one cycle for the PATROL and HPLC method.

---

## Conclusion

- The use of the PATROL system allowed the process chemist to make informed decisions rapidly to keep the impurities under control and reduce the loss of product from 5 kg (if HPLC had been utilized) to 1.5 kg
- PATROL can provide fast quantification of product, reactants, and impurities not currently available from traditional PAT tools
- PATROL is a complementary technique to traditional PAT spectroscopic approaches
- PATROL allows for rapid monitoring and optimization of large scale reactions with short cycle times. Total cycle time reduced from 10 minutes to 3 minutes

---

## Featured Products

---



[PATROL UPLC Process Analysis System <https://www.waters.com/10046886>](https://www.waters.com/10046886)

[Empower 3 Chromatography Data Software <https://www.waters.com/10190669>](https://www.waters.com/10190669)

720005934, March 2017

©2019 Waters Corporation. All Rights Reserved.

[Terms of Use](#)

[Privacy](#)

[Trademarks](#)

[Sitemap](#)

[Careers](#)

[Cookies](#)

[Préférences de cookies](#)