

# LC-MS/MS Analysis of Urinary Benzodiazepines and Z-drugs via a Simplified, Mixed-Mode Sample Preparation Strategy

---

Jonathan P. Danaceau, Erin E. Chambers

Waters Corporation

*For forensic toxicology use only.*

---

## Abstract

This application note describes a rapid and simplified solid phase extraction protocol and LC-MS/MS method for the analysis of urinary benzodiazepines and metabolites.

The unique water wettable nature of the Oasis MCX Sorbent enables the elimination of the common conditioning and equilibration steps without any loss in recovery or reproducibility. This property of Oasis also enables the entire hydrolysis step to be conducted within the wells of the Oasis MCX  $\mu$ Elution Plate, eliminating time consuming and error-prone transfer steps, reducing the total number of post-incubation steps from 9 to 5. Combining this extraction procedure with the chromatography of the CORTECS C<sub>18</sub>+ Column, and the sensitive and reproducible quantification of the Xevo TQ-S micro mass spectrometer, results in a rapid and efficient analysis method that is also exceptionally accurate. This method is simpler, faster, and easier, than liquid-liquid extraction and cleaner than reversed-phase SPE while providing excellent sensitivity, accuracy and precision for the analysis of this important class of compounds.

## Benefits

---

- Rapid, simplified sample preparation of urinary benzodiazepines
  - Significant savings in solvent usage and disposal vs. liquid-liquid extraction
  - Consistent recovery for all compounds
  - Excellent accuracy and reproducibility
  - All sample pretreatment and extraction performed in-well, eliminating transfer steps
  - Reduced matrix effects vs. reversed-phase SPE
- 

## Introduction

Benzodiazepines are frequently prescribed drugs used for their sedative, anxiolytic, and hypnotic properties.<sup>1</sup> They work by potentiating the inhibitory neurotransmitter gamma-amino butyric acid (GABA). Nationally, overdose deaths from benzodiazepines have risen 600% from under 1,600/year in 2001 to 8,000 in 2014, greater than any other drug class with the exception of heroin.<sup>2</sup> So-called “Z-drugs” (zolpidem and zopiclone) are commonly used sleep aids that act in a similar manner to benzodiazepines.<sup>1</sup> While the use of LC-MS/MS for benzodiazepine analysis has increased in recent years, many published techniques still rely on labor intensive liquid-liquid extraction techniques.<sup>3-5</sup> Some of the drawbacks of these techniques include the need to process individual samples one by one, the use of toxic solvents, and the need to evaporate and reconstitute samples after extraction.

This application note details a sample preparation and LC-MS/MS analysis strategy for a comprehensive panel of benzodiazepines, metabolites, and Z-drugs for forensic toxicology use. Using an abbreviated, modified solid phase extraction (SPE) method, Waters Oasis MCX  $\mu$ Elution Plates were used to rapidly extract this panel of drugs and metabolites from urine samples. All sample preparation steps, including enzymatic hydrolysis, were performed within the wells of the Oasis MCX  $\mu$ Elution Plates, and the extraction method was simplified by eliminating conditioning and equilibration steps. This enabled a streamlined workflow that minimized sample transfer steps while still achieving excellent and reproducible quantitative results. Chromatographic separation was achieved using a CORTECS UPLC C<sub>18</sub> + Column while a Xevo TQ-S micro Mass Spectrometer was used for detection. Extraction recovery was efficient, averaging 91%, and the use of the mixed-mode sorbent reduced matrix effects compared to

reversed-phase SPE. The CORTECS UPLC C<sub>18</sub>+ Column enabled the baseline separation of all target analytes from internal standards with identical nominal masses. This eliminated the risk of chromatographic interference between the labeled internal standards and the native compounds. All within and between batch quality control samples had mean accuracies within 5% of nominal values.

This method was also performed at HPLC scale using a CORTECS UPLC C<sub>18</sub>+ 2.7 µm Column (3.0 x 100 mm) (p/n 186007372). The same efficient separation was seen as with the 1.6 µm column (p/n 186007402), with backpressures that remained under 4000 psi and a separation time that was increased by only 30%.

---

## Experimental

All standards were obtained from Cerilliant (Round Rock, TX). Deuterated internal standards were used for all compounds with the exception of flurazepam. Stock solutions were prepared in methanol. Working standards were prepared daily by diluting stock standards in 80:20 water:methanol. Calibrators and QC samples were prepared in urine from working standards. All analytes are listed in Table 1, along with retention times and MS transitions and parameters.

Compound	RT	M+H+	MRM product ions	Cone voltage	Collision energy
1 N-desmethyl zopiclone	1.07	375.1	245.0 331.0	6 6	14 8
2 Zopiclone	1.13	389.1	245.0 111.9	8 8	12 58
3 Zolpidem	1.62	308.1	235.1 92.0	34 34	32 52
4 7-aminoclonazepam	1.92	286.1	121.0 222.1	50 50	26 30
5 Flurazepam	2.32	388.2	315.1 100.0	40 40	26 28
6 7-aminoflunitrazepam	2.36	284.1	135.0 226.9	34 34	26 22
7 Chlordiazepoxide	2.35	300.0	227.0 283.0	34 34	20 12
8 Midazolam	2.53	326.0	291.0 222.9	16 16	36 24
9 $\alpha$ -OH-midazolam	2.91	342.0	203.0 168.0	2 2	24 40
10 $\alpha$ -OH-triazolam	3.78	359.0	176.0 140.8	28 28	24 38
11 $\alpha$ -OH-alprazolam	3.77	325.1	297.1 243.1	50 50	25 30
12 Oxazepam <sup>1</sup>	3.84	289.0	103.9 243.0	50 50	30 20
13 Nitrazepam	3.87	282.1	180.1 236.0	50 50	36 20
14 Lorazepam	4.01	321.0	277.0 229.0	50 50	20 30
15 Clonazepam	4.10	316.0	214.1 241.1	54 54	42 40
16 Alprazolam	4.35	309.1	205.0 281.1	50 50	40 26
17 Nordiazepam	4.36	271.0	140.0 165.0	50 50	30 28
18 Flunitrazepam	4.41	314.1	239.2 268.1	50 50	30 25
19 Temazepam	4.45	301.1	177.0 255.1	36 50	46 20
20 Triazolam	4.47	343.0	308.0 239.0	28 28	24 38
21 Diazepam	5.14	285.1	154.0 193.1	50 50	26 30

Table 1. Analyte list, retention times, and MS parameters for benzodiazepines and metabolites analyzed in this application.

<sup>1</sup>Oxazepam's parent ion was set at 289 to avoid interference with Nitrazepam-d5 seen with m/z 287.

## Sample pretreatment

200  $\mu\text{L}$  of urine was added to individual wells of an Oasis MCX  $\mu\text{Elution}$  Plate, along with 20  $\mu\text{L}$  of internal standard solution (250 ng/mL), and 200  $\mu\text{L}$  of 0.5 M ammonium acetate buffer (pH 5.0) containing 10  $\mu\text{L}$  of  $\beta$ -glucuronidase enzyme/mL of buffer (Sigma Aldrich, *P. vulgate*, 85k units/mL). The entire plate was incubated at 50  $^{\circ}\text{C}$  for 1 hr. and then quenched with 200  $\mu\text{L}$  of 4%  $\text{H}_3\text{PO}_4$ .

## SPE extraction

Pretreated samples were drawn into the sorbent bed by vacuum. All samples were subsequently washed with 200  $\mu\text{L}$  of 0.02 N HCl, followed by 200  $\mu\text{L}$  of 20% MeOH. After washing, the plate was dried under high vacuum (~15 inch Hg) for 30 seconds. Samples were eluted with 2 x 25  $\mu\text{L}$  of 60:40 ACN:MeOH containing 5% strong ammonia solution (Fisher, 28–30%). All samples were then diluted with 100  $\mu\text{L}$  of sample diluent (2% ACN:1% formic acid in MilliQ water). A graphical workflow of the extraction procedure is shown in Figure 1.

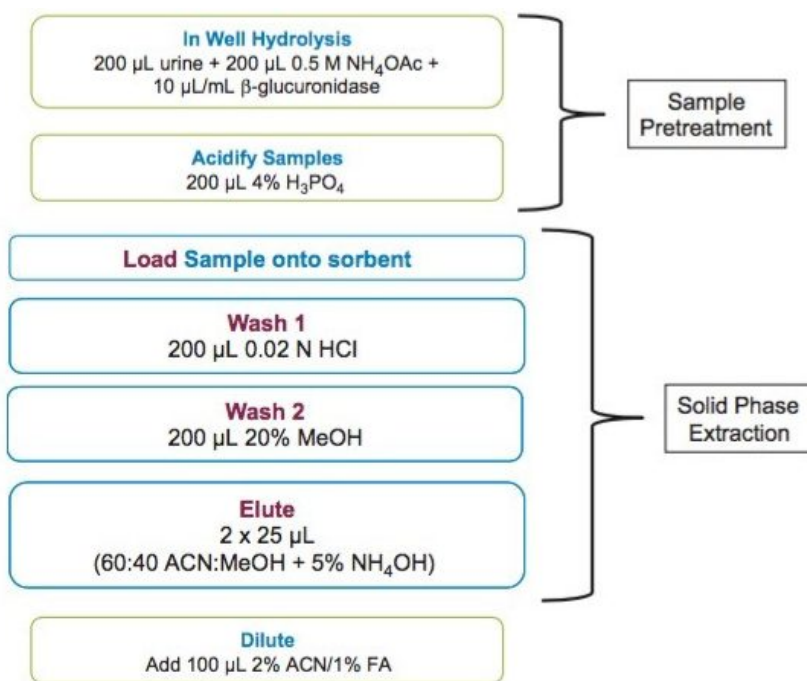

Figure 1. Details of the extraction method for the analysis of urinary benzodiazepines using Oasis MCX  $\mu$ Elution Plates. Enzymatic hydrolysis and sample pretreatment are performed in the wells of the extraction plate, minimizing transfer steps. Conditioning and equilibration steps are eliminated, significantly simplifying the procedure.

## Method conditions

### LC conditions

System:	ACQUITY UPLC I-Class (FL)
Column:	CORTECS UPLC C <sub>18</sub> + 1.6 $\mu$ m, 2.1 x 100 mm (p/n: 186007402)
Column temp.:	30 °C

Sample temp.:	10 °C
Injection volume:	5 µL
Flow rate:	0.5 mL/min
Mobile phase A (MPA):	0.01% Formic acid in MilliQ water
Mobile phase B (MPB):	0.01% Formic acid in acetonitrile (ACN)
Gradient:	Initial conditions were 90:10 MPA:MPB. The percentage of MPB was increased to 50% over five minutes, ramped up to 95% by 5.25 minutes, held at 95% for 0.75 minutes and returned to 10% over 0.1 minute.

## MS conditions

System:	Xevo TQ-S micro
Ionization mode:	ESI+
Detection:	MRM (transitions optimized for individual compounds, Table 1)
Capillary voltage:	0.5 kV
Collision energy:	Optimized for individual compounds (See Table 1)
Cone voltage:	Optimized for individual compounds (See Table 1)

## Data management

MassLynx Software with TargetLynx Application Manager

Analyte recovery was calculated according to the following equation:

$$\%Recovery = \left( \frac{Area A}{Area B} \right) \times 100\%$$

Where A = the peak area of an extracted sample and B = the peak area of an extracted matrix sample in which the compounds were added post-extraction.

---

## Results and Discussion

### Chromatography

All test compounds are listed in Table 1, and their chromatography is shown in Figure 2. Table 1 also lists the retention times and MS conditions of all compounds. Several columns were evaluated for this application, but the selectivity of the CORTECS UPLC C<sub>18</sub><sup>+</sup> Column enables the baseline separation of all potentially interfering peaks. Two key pairs are shown in Figure 3. While clonazepam-d4 (R.T. 4.08) generates a slight contribution to the primary lorazepam MRM (323>277), the two peaks are baseline separated. Even at the LLOQ (0.5 ng/mL), the clonazepam IS does not interfere with lorazepam and does not affect quantification of the peak. Another critical pair is alprazolam-d5 and flunitrazepam. In this case, flunitrazepam makes a contribution that can be seen in the MRM trace of alprazolam-d5 (314.1>210.1). However, the baseline separation of these peaks ensures that even at the ULOQ (500 ng/mL) the baseline separation prevents flunitrazepam from affecting the integration and quantification of the alprazolam IS.



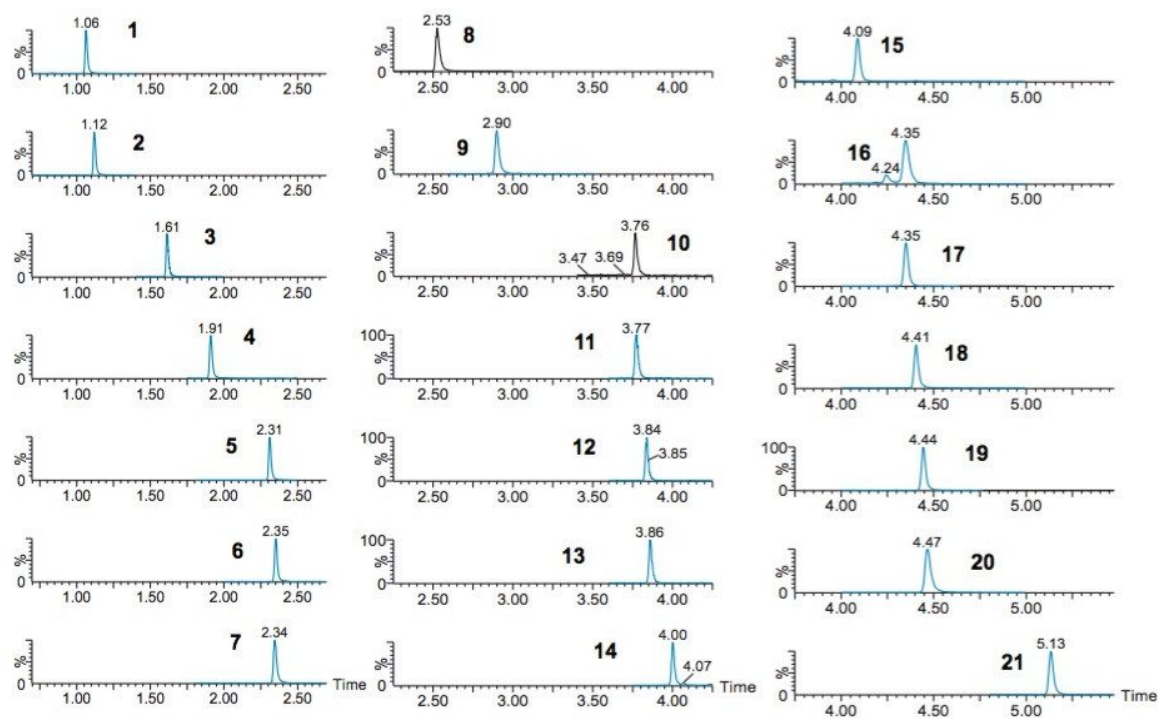

Figure 2. Chromatography of benzodiazepines analyzed in this application. See Table 1 for compound key. Column: CORTECS UPLC  $C_{18}+$  1.6  $\mu$ m, 2.1 x 100 mm.

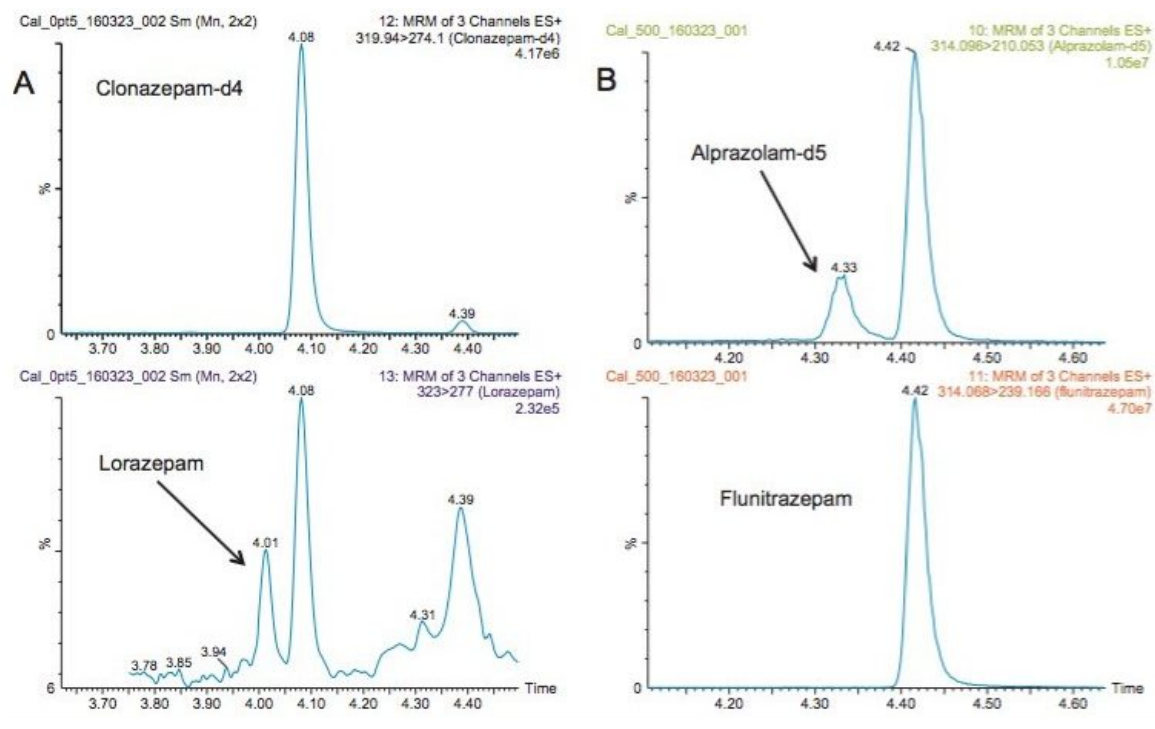

Figure 3. Chromatographic separation of key analyte pairs on the CORTECS UPLC  $C_{18}+ 1.6 \mu m$  Column. A. Clonazepam-d4 contributes to the lorazepam MRM but is baseline separated on this column. B. Alprazolam-d5 at 4.33 minutes is baseline separated from flunitrazepam at 4.42 minutes.

This panel was also analyzed on an HPLC scale using a CORTECS UPLC  $C_{18}+ 2.7 \mu m$  Column (3.0 x 100 mm) and an ACQUITY UPLC H-Class System. Table 2 compares the retention times of the UPLC and HPLC methods. All critical separations were maintained under HPLC conditions. The maximum system pressure stayed below 4000 psi. The retention time of diazepam, the latest eluting peak, only increased from 5.14 to 6.69, a 30% increase, and the solvent ramp duration increased from seven to nine minutes. The increase in retention time was likely due to the decreased linear velocity of the mobile phase resulting from the larger interior diameter of the HPLC column (3.0 mm vs 2.1 mm) and the decrease in the slope of the solvent ramp. If run on a traditional HPLC system, the increase in dwell volume would likely result in an increase in peak width. Nevertheless, the scalability of the CORTECS UPLC  $C_{18}+$  Column should make this adjustment straightforward. While ACQUITY UPLC will provide the fastest and most efficient separation, this enables the method to be performed on HPLC instrumentation if necessary.

## Recovery and matrix effects

Figure 4 shows the composite extraction recoveries of the entire panel of compounds from four separate experiments. Recoveries ranged from 76 to 102% with an average of 91%, demonstrating excellent extraction efficiency. The recoveries were consistent as well, with coefficients of variation (%CVs) ranging from 5.2% to 15%, with a mean of 8.6%. The extraction method was modified from a traditional MCX method for basic compounds. The first wash step was modified from aqueous 2% formic acid to 0.02 N HCl to account for the low pK<sub>a</sub>s of compounds such as clonazepam, flunitrazepam, and alprazolam and ensure ion-exchange retention on the MCX sorbent. A series of experiments performed during method development revealed that more than 20% methanol in the wash step resulted in loss of the acidic benzodiazepines, such as oxazepam, lorazepam, and temazepam. Thus, the second wash step consisted of 20% methanol, the strongest organic wash possible that did not result in analyte loss during the wash step. These modifications maximized reversed-phase and ion-exchange retention and enabled the highly efficient and most selective extraction of the entire panel of benzodiazepines.

	<b>Compound</b>	<b>RT-UPLC</b>	<b>RT-HPLC</b>
1	N-desmethyl zopiclone	1.07	1.98
2	Zopiclone	1.13	2.05
3	Zolpidem	1.62	2.58
4	7-aminoclonazepam	1.92	3.05
5	Flurazepam	2.32	3.37
6	7-aminoflunitrazepam	2.36	3.55
7	Chlordiazepoxide	2.35	3.39
8	Midazolam	2.53	3.57
9	$\alpha$ -OH-midazolam	2.91	3.98
10	$\alpha$ -OH-triazolam	3.78	4.95
11	$\alpha$ -OH-alprazolam	3.77	4.93
12	Oxazepam <sup>1</sup>	3.84	5.16
13	Nitrazepam	3.87	5.28
14	Lorazepam	4.01	5.32
15	Clonazepam	4.10	5.51
16	Alprazolam	4.35	5.52
17	Nordiazepam	4.36	5.78
18	Flunitrazepam	4.41	5.90
19	Temazepam	4.45	5.89
20	Triazolam	4.47	5.65
21	Diazepam	5.14	6.69

Table 2. UPLC and HPLC retention times for benzodiazepines and z-drugs.

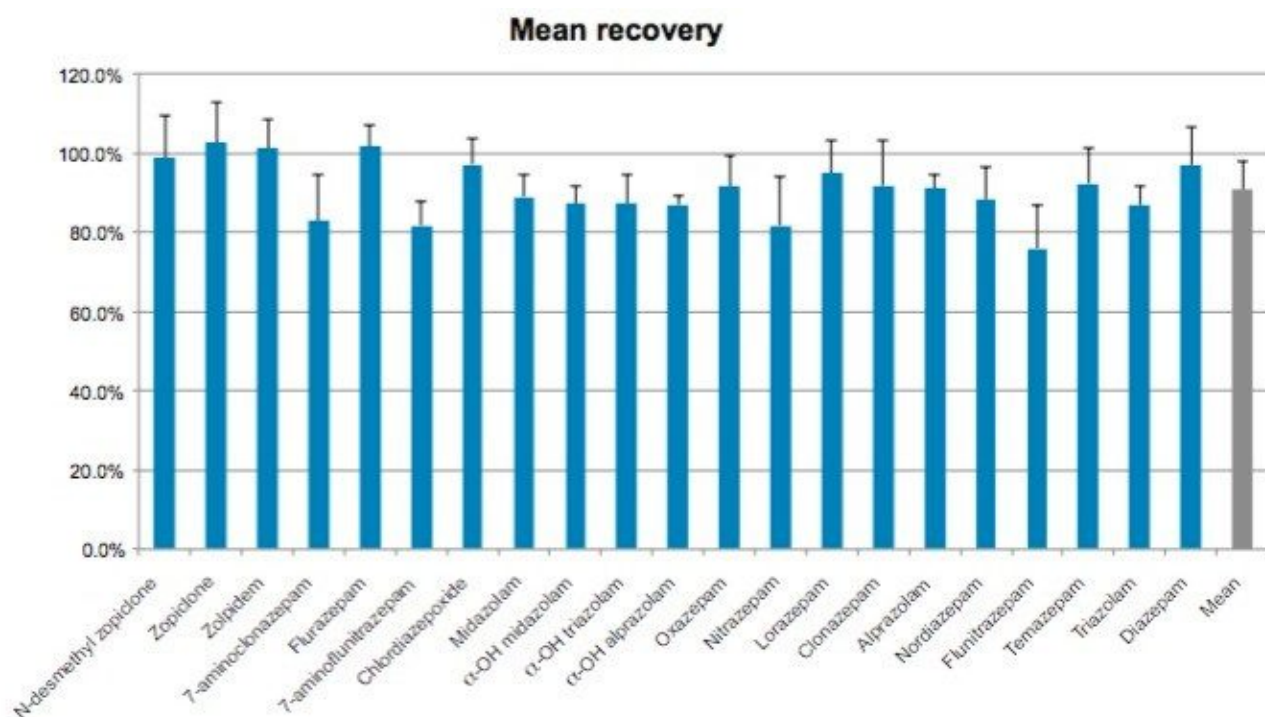

Figure 4. Extraction recovery for the compounds in this application. Values represent the mean of four individual extractions. Recoveries ranged from 76%–102.5% with an average recovery of 91%. Direct loading of the sorbent, without conditioning and equilibration had no impact on analyte recovery.

Two key benefits of this method take advantage of the water-wettable nature of the Oasis sorbent, the ability to directly load without conditioning and equilibration, and the ability to conduct all hydrolysis and pretreatment within the well of the SPE plate. The traditional six-step mixed-mode SPE method was simplified into just four steps. This was accomplished by eliminating the conditioning and equilibration steps. This simplification had no effect on the extraction efficiency of the method (data not shown), and is consistent with the water wettable nature of the Oasis sorbent. This also enables all sample hydrolysis and pretreatment to be performed within the wells of the 96-well plate, eliminating the need to transfer the sample from an incubation vessel to the SPE plate, a step that can be time consuming and error prone. After incubation within the wells of the Oasis MCX  $\mu$ Elution Plate, the samples were simply mixed with 4%  $H_3PO_4$  to quench the hydrolysis reaction and ionize the basic benzodiazepines, which were then drawn directly onto the sorbent. No leakage or well blockages were seen in any of the method development or validation experiments. Overall, this method reduces the number of post-incubation

steps from nine to five by eliminating conditioning, equilibration, the transfer of samples to the SPE device, and sample evaporation compared to a traditional SPE workflow.

Matrix effects are shown in Figure 5. As with analyte recoveries, matrix effects were equivalent between the direct loaded samples and those in which the sorbent was conditioned and equilibrated. Matrix effects were also compared to traditional reversed phase extraction with Oasis PRiME HLB. Absolute matrix effects were 17.7% for Oasis MCX  $\mu$ Elution plate prepared samples vs. 25.3% for Oasis PRiME HLB prepared samples (data not shown), demonstrating the superior cleanup of mixed-mode SPE for this group of analytes.

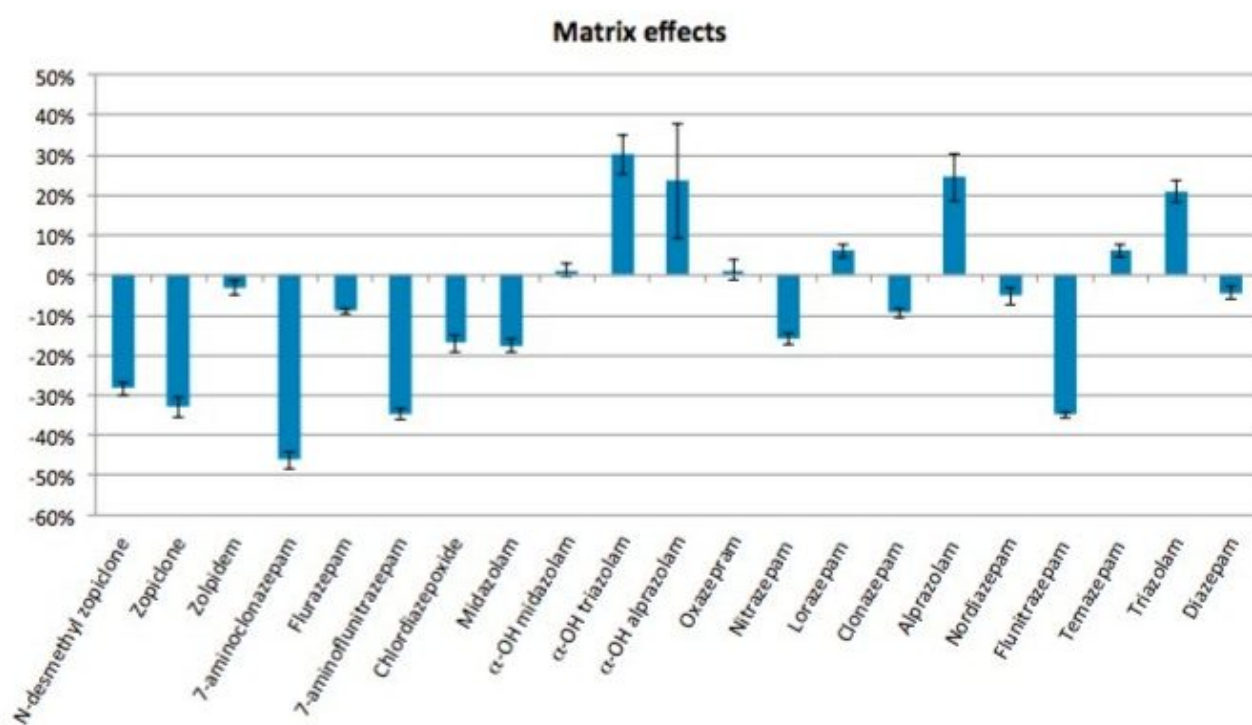

Figure 5. Matrix effects for benzodiazepines. Absolute matrix effects were reduced from 25.3% to 17.7% by using Oasis MCX mixed-mode SPE Plates vs. reversed-phase sorbent (Oasis HLB).

## Quantitative results

Calibration curves ranged from 0.5 ng/mL through 500 ng/mL for all compounds. All compounds had LOQs of 0.5 ng/mL and ULOQs of 500 ng/mL. Quality control samples were prepared at 1.5, 7.5, 75, and 300 ng/mL. A calibration summary is shown in Table 3. Six of the curves were fitted with a  $1/x$

weighted linear curve, while 15 were best fit with a 1/x weighted quadratic curve. Figure 6 shows examples of compounds best fit with a linear curve (nitrazepam, alprazolam), and a quadratic fit curve (diazepam, 7-aminoclonazepam). Regardless of the function used, fits were excellent and fit for purpose for the analytical needs of the method. Seventeen compounds had R<sup>2</sup> values of 0.999 or greater, and the remaining compounds had R<sup>2</sup> values of 0.997 or greater. Table 3 also shows that the mean % deviations for all compounds were less than 10%. Additionally, Tables 4 and 5 show the results of within-batch and between-batch QC results. The within-batch results show both excellent accuracy and precision. The mean accuracies for all compounds at the four QC levels were 107.8%, 98.5%, 97.5%, and 97.5%. For the highest three QC values (7.5, 75, and 300 ng/mL) all individual accuracies were within 10% of target values and all %CVs were less than 10%. The between-batch results shown in Table 5 were, if anything, even better. Mean accuracies were 102.1%, 99.3%, 98.2%, and 96.8% at the four QC levels. Individual CVs ranged from 1.1% to 9.0%. These high levels of accuracy and precision demonstrate the consistency and reliability of the Oasis MCX sorbent and extraction technique, and demonstrate that there is no compromise of result quality, even with the in-well hydrolysis and direct sorbent loading used in this assay. They also show that the quadratic curves used are fit for purpose and meet the needs of the assay.

Name	R <sup>2</sup>	Lin/Quad	Mean %Dev
N-desmethyl zopiclone	0.999	L	5.4
Zopiclone	0.998	L	5.4
Zolpidem	0.999	Q	4.1
7-aminoclonazepam	1.000	Q	2.3
Flurazepam	0.998	Q	4.1
7-aminoflunitrazepam	0.997	L	6.2
Chlordiazepoxide	1.000	Q	3.4
Midazolam	1.000	Q	4.8
α-OH midazolam	0.999	Q	4.0
α-OH triazolam	1.000	Q	4.4
α-OH alprazolam	0.999	Q	9.0
Oxazepam	1.000	Q	6.2
Nitrazepam	0.999	L	4.6
Lorazepam	0.999	Q	4.4
Clonazepam	1.000	Q	6.2
Alprazolam	0.998	L	9.9
Nordiazepam	0.999	Q	6.6
Flunitrazepam	0.999	L	3.9
Temazepam	0.999	Q	5.3
Triazolam	0.999	Q	4.1
Diazepam	0.999	Q	3.7

Table 3. Calibration summary for all compounds in this application. The mean %deviation refers to the average of the absolute value of the deviations of all points in the curve.



Compound name: Nitrazepam  
Correlation coefficient:  $r = 0.999547$ ,  $r^2 = 0.999094$   
Calibration curve:  $1.27402 \cdot x + 0.0853718$   
Response type: Internal Std (Ref 25), Area \* (IS Conc./IS Area)  
Curve type: Linear, Origin: Exclude, Weighting: 1/x, Axis trans: None

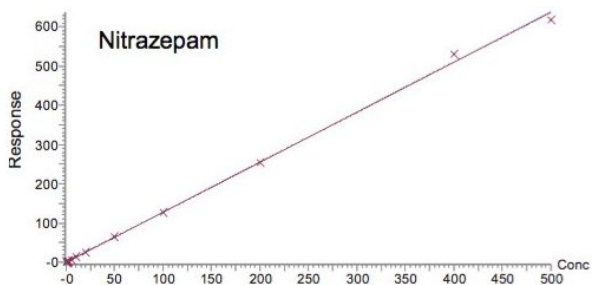

Compound name: Diazepam  
Coefficient of Determination:  $R^2 = 0.999372$   
Calibration curve:  $-0.000745139 \cdot x^2 + 1.13705 \cdot x + 0.119716$   
Response type: Internal Std (Ref 41), Area \* (IS Conc./IS Area)  
Curve type: 2nd Order, Origin: Exclude, Weighting: 1/x, Axis trans: None

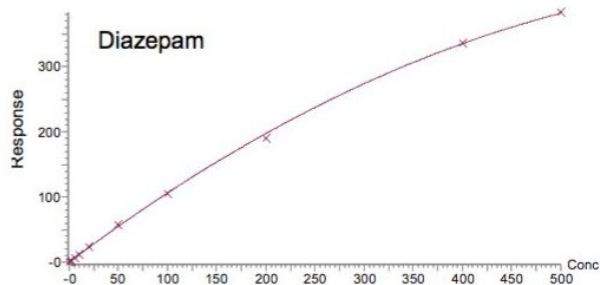

Compound name: Alprazolam  
Correlation coefficient:  $r = 0.999219$ ,  $r^2 = 0.998439$   
Calibration curve:  $1.0372 \cdot x + 0.0774353$   
Response type: Internal Std (Ref 31), Area \* (IS Conc./IS Area)  
Curve type: Linear, Origin: Exclude, Weighting: 1/x, Axis trans: None

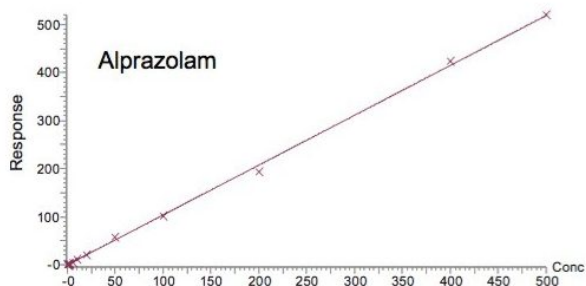

Compound name: 7-aminoclonazepam  
Coefficient of Determination:  $R^2 = 0.999569$   
Calibration curve:  $-0.000577581 \cdot x^2 + 1.2849 \cdot x + 0.0853396$   
Response type: Internal Std (Ref 8), Area \* (IS Conc./IS Area)  
Curve type: 2nd Order, Origin: Exclude, Weighting: 1/x, Axis trans: None

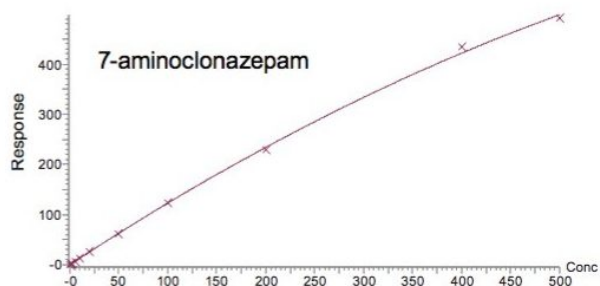

Figure 6. Representative calibration curves of benzodiazepines. Nitrazepam and alprazolam were fit with a 1/x linear curve, while diazepam and 7-aminoclonazepam were best fit with a quadratic 1/x weighted curve.

Name	QC 1.5		QC 7.5		QC 75		QC 300		Mean
	Mean	%CV	Mean	%CV	Mean	%CV	Mean	%CV	
N-desmethyl zopiclone	103.6%	7.3%	99.3%	3.1%	99.8%	2.0%	98.2%	3.9%	100.2%
Zopiclone	101.4%	7.4%	100.6%	3.2%	100.9%	2.3%	98.1%	4.0%	100.3%
Zolpidem	102.7%	6.7%	100.1%	2.5%	96.8%	0.9%	93.4%	4.2%	98.2%
7-aminoclonazepam	102.3%	8.1%	96.5%	2.6%	95.4%	1.0%	96.8%	3.5%	97.8%
Flurazepam	111.0%	9.0%	95.8%	4.5%	96.0%	2.1%	99.2%	4.7%	100.5%
7-aminoflunitrazepam	101.9%	10.9%	95.8%	4.5%	98.4%	1.7%	97.5%	3.6%	98.4%
Chlordiazepoxide	100.7%	9.5%	97.8%	4.2%	98.5%	1.0%	100.3%	6.1%	99.3%
Midazolam	107.0%	9.9%	98.3%	2.3%	98.6%	2.3%	99.4%	2.8%	100.8%
$\alpha$ -OH midazolam	107.4%	8.1%	99.5%	2.3%	99.0%	1.6%	101.1%	3.8%	101.8%
$\alpha$ -OH triazolam	109.9%	9.2%	95.1%	2.3%	93.1%	1.6%	94.5%	5.4%	98.1%
$\alpha$ -OH alprazolam	114.5%	12.6%	98.9%	5.2%	94.1%	4.5%	95.4%	8.3%	100.7%
Oxazepam	105.4%	6.3%	94.6%	3.2%	96.9%	1.4%	95.6%	3.1%	98.1%
Nitrazepam	108.8%	7.7%	96.8%	2.6%	97.0%	0.8%	98.2%	3.5%	100.2%
Lorazepam	107.0%	7.2%	95.5%	2.0%	96.1%	2.0%	97.4%	4.0%	99.0%
Clonazepam	106.7%	10.6%	97.2%	3.0%	95.4%	2.0%	94.6%	3.8%	98.4%
Alprazolam	116.8%	10.0%	99.3%	5.7%	98.7%	4.4%	101.3%	6.1%	104.0%
Nordiazepam	110.9%	10.1%	103.2%	2.4%	99.2%	1.6%	96.3%	3.0%	102.4%
Flunitrazepam	111.1%	8.2%	101.4%	2.4%	97.2%	1.9%	100.7%	4.3%	102.6%
Temazepam	110.6%	8.0%	102.8%	2.7%	98.5%	1.4%	95.4%	6.0%	101.8%
Triazolam	113.6%	8.4%	103.4%	2.5%	101.1%	2.4%	99.4%	1.8%	104.4%
Diazepam	110.3%	7.9%	101.5%	2.3%	97.3%	0.8%	95.3%	3.6%	101.1%
<b>Mean</b>	<b>107.8%</b>		<b>98.7%</b>		<b>97.5%</b>		<b>97.5%</b>		

Table 4. Within-batch QC results. N=6. Mean values show the average for each compound and the average for all compounds at each QC level.

Name	QC 1.5		QC 7.5		QC 75		QC 300		Mean
	Mean	%CV	Mean	%CV	Mean	%CV	Mean	%CV	
N-desmethyl zopiclone	99.2%	3.8%	96.7%	2.4%	96.6%	2.9%	97.1%	4.7%	97.4%
Zopiclone	97.7%	3.2%	96.7%	3.4%	98.0%	2.8%	96.2%	3.5%	97.2%
Zolpidem	99.4%	3.4%	98.8%	1.5%	95.8%	1.1%	91.7%	1.6%	96.4%
7-aminoclonazepam	100.4%	1.9%	95.6%	1.0%	93.8%	2.4%	95.1%	2.0%	96.2%
Flurazepam	103.6%	7.1%	97.6%	4.3%	99.3%	7.4%	97.6%	5.0%	99.5%
7-aminoflunitrazepam	99.3%	2.3%	93.7%	2.3%	96.1%	4.7%	97.0%	3.2%	96.5%
Chlordiazepoxide	100.5%	1.1%	100.3%	2.1%	99.3%	1.5%	98.4%	3.2%	99.6%
Midazolam	103.7%	4.4%	104.2%	5.4%	102.1%	3.1%	98.9%	2.0%	102.2%
$\alpha$ -OH midazolam	103.4%	4.3%	102.5%	4.7%	100.8%	5.0%	99.1%	2.5%	101.4%
$\alpha$ -OH triazolam	101.5%	8.4%	98.8%	4.9%	98.3%	4.9%	95.1%	2.6%	98.4%
$\alpha$ -OH alprazolam	104.4%	9.6%	101.4%	2.2%	99.1%	5.9%	97.7%	2.4%	100.7%
Oxazepam	100.4%	4.3%	98.5%	4.1%	98.2%	4.7%	97.6%	4.6%	98.7%
Nitrazepam	102.0%	6.2%	95.8%	1.3%	95.7%	2.4%	98.1%	1.8%	97.9%
Lorazepam	100.3%	6.9%	100.2%	4.2%	100.8%	5.4%	98.7%	4.9%	100.0%
Clonazepam	102.0%	4.9%	98.2%	3.0%	97.5%	3.3%	95.2%	4.5%	98.2%
Alprazolam	107.0%	8.7%	94.6%	4.7%	95.0%	4.6%	98.8%	4.5%	98.9%
Nordiazepam	106.1%	9.0%	106.7%	3.7%	101.7%	4.6%	95.4%	5.2%	102.5%
Flunitrazepam	101.8%	8.1%	98.2%	2.8%	96.3%	2.6%	96.3%	7.8%	98.1%
Temazepam	102.9%	7.3%	101.6%	1.2%	97.5%	2.8%	94.7%	1.8%	99.2%
Triazolam	104.4%	8.4%	102.4%	2.3%	99.9%	3.2%	98.2%	3.4%	101.2%
Diazepam	104.3%	6.5%	103.8%	2.1%	99.6%	4.1%	94.9%	7.6%	100.6%
<b>Mean</b>	<b>102.1%</b>		<b>99.3%</b>		<b>98.2%</b>		<b>96.8%</b>		

Table 5. Between-batch QC results. Values represent the mean and %CV of four separate extraction batches. Mean values show the average for each compound and the average for all compounds at each QC level.

## Conclusion

This application note describes a rapid and simplified solid phase extraction protocol and LC-MS/MS method for the analysis of urinary benzodiazepines and metabolites for forensic toxicology use. The unique water wettable nature of the Oasis MCX sorbent enables the elimination of the common conditioning and equilibration steps without any loss in recovery or reproducibility. This property of Oasis also enables the entire hydrolysis step to be conducted within the wells of the Oasis MCX  $\mu$ Elution plate, eliminating time consuming and error-prone transfer steps, reducing the total number of post-incubation steps from nine to five. This extraction procedure combining the chromatography of the CORTECS UPLC C<sub>18</sub>+ Column and the sensitive and reproducible quantification of the Xevo TQ-S micro results in a rapid and efficient analysis method that is also exceptionally accurate. This method is

simpler, faster, and easier than liquid-liquid extraction. It is also cleaner than reversed-phase SPE while providing excellent sensitivity, accuracy, and precision for the analysis of this important class of compounds.

---

## References

1. Jufer-Phipps R, Levine, B. Benzodiazepines. In: *Principles of Forensic Toxicology*, B. Levine (Eds). AACC Press, Washington, D.C. 2013; 237–270.
2. Karithanom, M. Number of Deaths from Prescription Drugs, National Institute of Drug Abuse, National Overdose Deaths, CDC Wonder, 2015; <https://www.drugabuse.gov/related-topics/trends-statistics/overdose-death-rates>.
3. Laloup M, Fernandez M.d.MR, De Boeck G, Wood M, Maes V, Samyn N. Validation of a Liquid Chromatography-Tandem Mass Spectrometry Method for the Simultaneous Determination of 26 Benzodiazepines and Metabolites, Zolpidem and Zopiclone, in Blood, Urine, and Hair. *Journal of Analytical Toxicology*, 2005; 29(7):616–626.
4. Marin SJ, Coles R, Merrell M, McMillin G.A. Quantitation of Benzodiazepines in Urine, Serum, Plasma, and Meconium by LC-MS-MS. *Journal of Analytical Toxicology*. 2008; 32(7): 491–498.
5. Marin SJ, Roberts M, Wood M, McMillin GA. Sensitive UPLC–MS/MS Assay for 21 Benzodiazepine Drugs and Metabolites, Zolpidem and Zopiclone in Serum or Plasma. *Journal of Analytical Toxicology*. 2012;36(7), 472–476.

---

## Featured Products

[Xevo TQ-S micro Triple Quadrupole Mass Spectrometry <https://www.waters.com/134798856>](https://www.waters.com/134798856)

[ACQUITY UPLC I-Class PLUS System <https://www.waters.com/134613317>](https://www.waters.com/134613317)

[ACQUITY UPLC H-Class PLUS System <https://www.waters.com/10138533>](https://www.waters.com/10138533)

---

MassLynx Software <<https://www.waters.com/513164>>

TargetLynx Application Manager <<https://www.waters.com/513791>>

720005973, April 2017

©2019 Waters Corporation. All Rights Reserved.

[使用条款](#) [隐私](#) [商标](#) [招聘](#) [Cookie](#) [Cookie设置](#)

沪ICP备06003546号-2 京公网安备 31011502007476号